

# UCR211

## DIVERSITY UHF RECEIVER



## OPERATING INSTRUCTIONS



## TABLE OF CONTENTS

<b>GENERAL TECHNICAL DESCRIPTION</b> .....	<b>4</b>
DIVERSITY RECEPTION .....	4
RF FREQUENCY TRACKING FRONT-END AND MIXER .....	4
MICROCONTROLLER, PLL AND VCO CIRCUITS .....	4
IF AMPLIFIERS AND SAW FILTERS .....	4
DIGITAL PULSE COUNTING DETECTOR .....	4
TRI-MODE DYNAMIC FILTER .....	4
PILOT TONE MUTE .....	5
SMART SQUELCHTM .....	5
OUTPUT LEVEL ADJUST .....	5
TEST TONE .....	5
BATTERIES .....	5
POWER SUPPLY .....	6
LCD DISPLAY .....	6
POWER UP SEQUENCE .....	6
POWER OFF .....	6
<b>FRONT PANEL CONTROLS AND INDICATORS</b> .....	<b>7</b>
LCD SCREEN .....	7
MENU BUTTON .....	7
SELECT UP/DOWN BUTTONS .....	7
POWER ON/OFF SWITCH .....	7
<b>REAR PANEL FEATURES</b> .....	<b>7</b>
XLR AUDIO OUTPUT JACK .....	7
POWER INPUT JACK .....	7
<b>MAIN WINDOW (LCD)</b> .....	<b>8</b>
<b>MENU SELECTIONS FROM MAIN WINDOW</b> .....	<b>9</b>
FREQUENCY WINDOW .....	9
BATTERY LEVEL WINDOW .....	9
SETUP WINDOW .....	9
LEVEL .....	9
TONE .....	9
TTXBAT .....	9
<b>FREQUENCY SCAN MODE</b> .....	<b>10</b>
SCAN AND VIEW WINDOW ELEMENTS .....	10
FINE VIEW WINDOW ELEMENTS .....	10
<b>ANTENNA USE AND PLACEMENT</b> .....	<b>11</b>
<b>INSTALLATION AND OPERATING INSTRUCTIONS</b> .....	<b>12</b>
FINDING CLEAR FREQUENCIES .....	12
LOCKING AND UNLOCKING THE UCR211 FRONT PANEL CONTROLS ..	13
<b>REPLACING THE BATTERY</b> .....	<b>14</b>
<b>UCR211 REPLACEMENT PARTS and ACCESSORIES</b> .....	<b>15</b>
<b>TROUBLESHOOTING</b> .....	<b>16</b>
<b>SPECIFICATIONS AND FEATURES</b> .....	<b>17</b>
<b>SERVICE AND REPAIR</b> .....	<b>18</b>
<b>RETURNING UNITS FOR REPAIR</b> .....	<b>18</b>
<b>LIMITED ONE YEAR WARRANTY</b> .....	<b>Back Cover</b>

## GENERAL TECHNICAL DESCRIPTION

The UCR211 is a portable, high performance, triple-conversion, frequency synthesized, UHF receiver fully compatible with all Lectrosonics 200 series transmitters. The RF performance is extremely stable over a very wide temperature range, making the UCR211 perfectly suited to the rough environmental conditions found in the field. The proprietary audio processing includes a dual-band compandor for very low distortion and a superior signal to noise ratio. The Smart Squelch system is operated by a pilot tone and mutes the audio output directly at the output connector.

The UCR211 features a menu-driven LCD graphic display and a three button control panel as a convenient means of viewing and altering user settings. The Main Window, for example, shows the pilot tone indicator, antenna diversity phase, RF level, audio level, receiver battery status and transmitter battery status. It is also possible to bypass the pilot tone from the Main Window. Other display windows show operating frequency, audio output level, battery status in tenths of volts, test tone status and provide for selection of levels or functions using the select buttons. The frequency scan mode provides a graphical means of observing all signals “on the air” within the frequency range of the receiver in order to find operating frequencies that are free of interference.

### DIVERSITY RECEPTION

The UCR211 antenna phase diversity technology with SMART Diversity™ minimizes dropouts in situations where multi-path reflections can cause serious problems. The phase diversity network and PIN diode RF switches are controlled by the microprocessor using a sophisticated algorithm. This design keeps the receiver compact enough for camera mounting or shoulder bag applications.

### RF FREQUENCY TRACKING FRONT-END AND MIXER

The receiver is frequency agile and can be set to operate on any one of 256 frequencies within the tuning range. To significantly reduce unwanted interference and intermodulation problems, the UCR211 has a frequency selective front-end section that tracks and tunes to the desired signal frequency and rejects or “tunes out” unwanted interfering signals. The design consists of four varactor tuned ceramic transmission line resonators controlled by the microprocessor to provide good selectivity. The low noise high current RF amplifier was designed with feedback regulation for stability and precise gain in order to handle stronger RF signals without output overload. The first mixer is of new GaAs technology that has a very high third order intercept point. This produces a robust front-end that is as selective as fixed single frequency designs and is suitable for use in close proximity to other receivers and transmitters commonly used in field production “bag” systems.

### MICROCONTROLLER, PLL AND VCO CIRCUITS

The 8-bit microprocessor is truly the “heart” of the UCR211 receiver. It monitors user command inputs from the front panel control buttons and numerous other internal signals such as RF level, audio levels, pilot tone levels and external/internal power voltages. Outputs from the microcontroller operate the front-end tuning, PLL/VCO circuits, antenna phase switch, drive the LCD display and backlight, and control the squelch and audio output attenuator. The microcontroller also generates an audio test tone used to adjust input levels of the equipment being fed by the receiver. The UCR211 design and the advanced technology of the microprocessor control arguably set a new standard in wireless microphone development.

### IF AMPLIFIERS AND SAW FILTERS

The first IF low noise amplifier is controlled with feedback regulation and drives the first of two quartz SAW (Surface Acoustical Wave) filters. The 244 MHz SAW filters combine sharp tuning, constant group delay, wide bandwidth and excellent temperature stability, far superior to conventional LC filters. The 244 MHz first IF signal is converted to 10.7 MHz, filtered through two ceramic filters for sharp selectivity, then converted to 300 kHz in one integrated circuit.

### DIGITAL PULSE COUNTING DETECTOR

The UCR211 receiver uses an elegantly simple, yet highly effective digital pulse detector to demodulate the FM signal, rather than a conventional quadrature detector. This unusual design eliminates thermal drift, improves AM rejection, and provides very low audio distortion.

### TRI-MODE DYNAMIC FILTER

The audio signal is passed through a “dynamic noise reduction circuit” that automatically controls the audio cutoff frequency. The cutoff frequency of this filter is varied automatically by measuring the amplitude and frequency of the audio signal and the quality of the RF signal. The audio bandwidth is held only to that point necessary to pass the highest frequency audio signal present at a given moment. This results in a dramatic reduction of the higher frequency “hiss” normally present particularly with low RF signal levels. During passages of high frequency audio content, this filter dynamically passes the signals with no decrease in high frequency content. This filter has proven very effective and is totally transparent.

### PILOT TONE MUTE

The UCR211 uses a pilot tone muting technique in order to protect against the reception of stray signals. The Lectrosonics transmitter adds an inaudible signal, known as the pilot tone, to the transmitted signal. The receiver detects (and removes) the pilot tone, and is thus able to

identify the desired signal and mute all others. (If the transmitter frequency differs from the receiver by as much as one “notch” or 100kHz, the pilot tone indicator on the receiver will drop out and the receiver audio will mute.)

When the receiver is powered up, receive audio is muted unless a proper pilot tone is detected. The pilot tone must be present for approximately one second before the signal is accepted.

The PILOT TONE BYPASS mode is set from the main window. In this mode, the received audio remains unmuted regardless of the presence or absence of a pilot tone. This mode is useful for locating a clear frequency, since any potential interference may be heard. It may also be used in situations where squelching behavior is undesirable. The PILOT TONE BYPASS disables the squelch, as described below.

### SMART SQUELCH™

The UCR211 employs a sophisticated squelching system in an attempt to deliver the cleanest possible audio during marginal conditions of reception. Any squelching system faces inevitable trade-offs: squelch too much and valuable audio information may be lost, squelch too little and excessive noise may be heard; respond too rapidly and the audio sounds “choppy,” respond too sluggishly and syllables or entire words can be cut off.

The UCR211 combines several techniques to achieve an optimal balance, removing distracting noise, without the squelching action itself becoming a distraction. One of these techniques involves waiting for a word or syllable to complete before squelching. Another incorporates recent squelching history and recent signal strength,

adjusting squelching behavior dynamically for the most serviceable result under variable conditions. Using these and other techniques, the UCR211 can deliver acceptable audio quality from otherwise unusable signals.

In the PILOT TONE BYPASS mode, the squelch system is disabled. Received audio remains unmuted at all times with this setting.

### OUTPUT LEVEL ADJUST

One of several setup screens is provided for adjusting the audio output level in 1dB steps from -50 to +10dBu using the UP and DOWN buttons on the front panel.

### TEST TONE

The UCR211 provides a 1kHz audio test tone at the XLR connector for level adjustment of connected equipment. The level is adjustable from -50 to +10 dBu in 1 dB steps to allow a precise match.

### BATTERIES

The UCR211 operates on two 9V alkaline or lithium batteries. Access to the battery compartment is gained by lifting one end and turning the rear panel door. NOTE: Do not use an alkaline *and* a lithium in the same unit. Standard or “heavy duty” batteries are not recommended.

### POWER SUPPLY

The UCR211 may be operated from an external DC source (see Specifications and Features section for allowed voltages.) The receiver has a built-in Poly-Fuse to protect the unit. This fuse resets if the power supply is disconnected for about 15 seconds. The power section

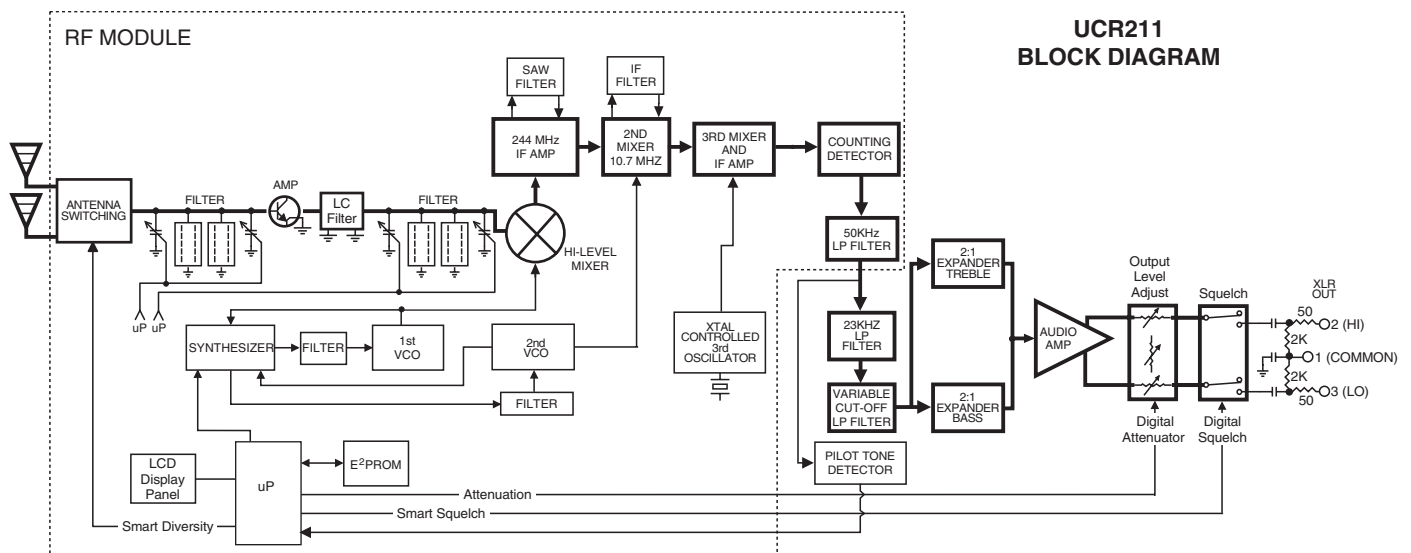

also has protection circuits that prevent damage to the receiver if a positive ground power source is applied.

## **LCD DISPLAY**

The display has four main windows. Pressing the MENU button rotates through each of these windows.

If the battery gets low on either transmitter or receiver, a message will interrupt the display every few seconds and flash a "LOW BATTERY" warning.

After power is turned off and back on again, the unit defaults to the main window and to the most recent frequency, audio level, transmitter battery type and locked/unlocked status settings. These settings are retained even if the batteries are removed.

## **POWER UP SEQUENCE**

The power-up sequence consists of four messages that appear automatically over a period of a few seconds after the power is switched on.

- 1) LOCKED or UNLOCKED status
- 2) The name LECTROSONICS
- 3) The model number and firmware revision
- 4) The frequency block of operation

After these introductory messages are displayed, the main window will appear.

The UCR211 is fully operational during the power up sequence and will immediately respond to button pushes made before the automatic sequence is completed. If a valid transmitter signal is already present when the receiver is turned on, the audio output will typically be engaged somewhere in the middle of the power-up sequence, following a brief delay to allow the audio circuits to stabilize.

(See LOCKING AND UNLOCKING THE UCR211 FRONT PANEL CONTROLS.)

## **POWER OFF**

When the power switch is moved to the OFF position the audio output is instantly muted (squelched) and the message "POWERING OFF.." is displayed briefly before switching off.

## FRONT PANEL CONTROLS AND INDICATORS

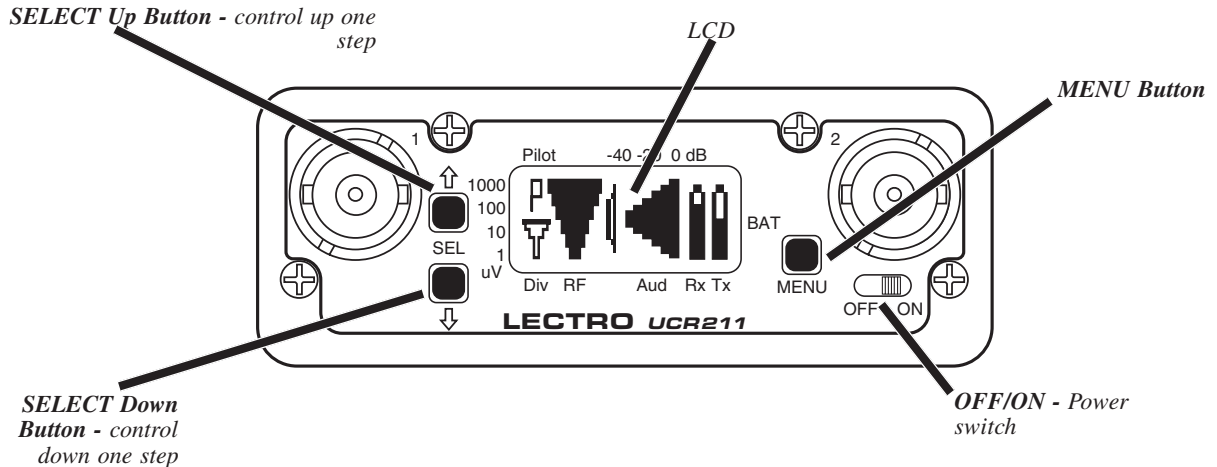

### LCD SCREEN

The LCD Screen is a graphics-type Liquid Crystal Display that is used to monitor system operation and configure the UCR201.

### MENU BUTTON

The MENU button steps through the four primary windows and setup screens.

### SELECT UP/DOWN BUTTONS

The SELECT Up/Down buttons are used to select various options within each display selection and for setting the operating frequency of the receiver.

### POWER ON/OFF SWITCH

The Power ON/OFF switch is used to applied battery or external power to the unit.

## REAR PANEL FEATURES

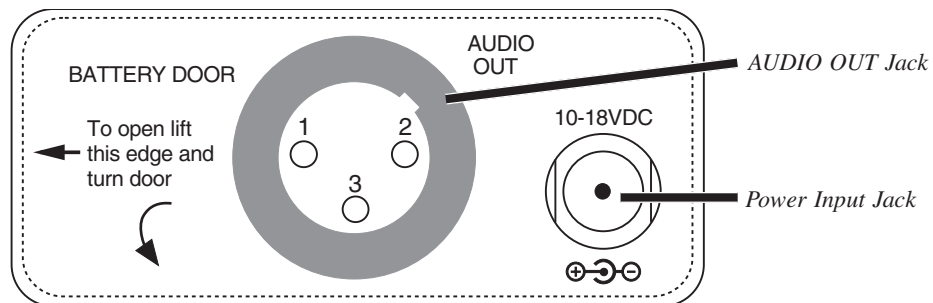

### XL R AUDIO OUTPUT JACK

This is a standard XLR configuration with pin 2 “positive” with reference to hand-held and plug-on transmitters. With lavalier microphones and belt-pack transmitters, however, phase will vary with different types of microphones (2-wire vs. 3-wire for example). The audio output is balanced but not floating, so an unbalanced signal is available using pin 1 as ground and pin 2 as signal, leaving pin 3 open.

### POWER INPUT JACK

The power input jack can accept 10-18 VDC - the center pin is positive and sleeve is ground. The input is diode protected to prevent damage if the power is applied with reversed polarity, but the unit will not work until the reversed polarity condition is fixed. Strain relief to avoid accidental disconnection can be provided with the included small hook and loop strip. Attach the adhesive

strip side to the side of the receiver or mount with the opening end of the strip up - place the cable in the strip and secure.

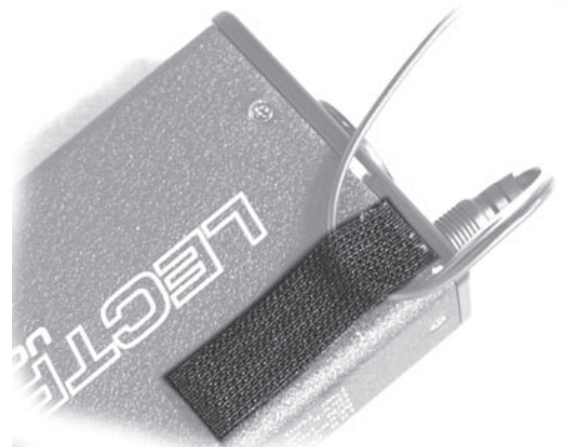



## MAIN WINDOW (LCD)

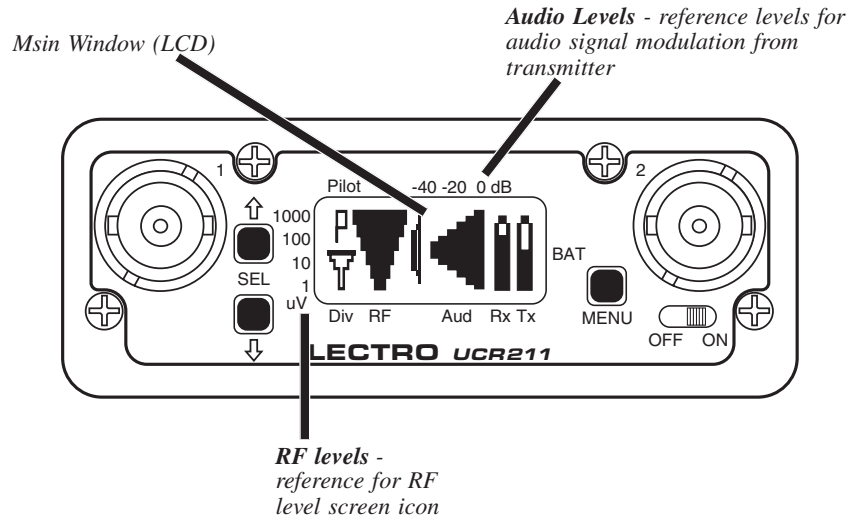

The Main Window displays information concerning the condition of the Pilot Tone, antenna phase, RF and audio signal levels and battery conditions for both the receiver and the associated transmitter. It is also the access

portal to menu selections for setting up the receiver and searching for clear frequency channels. (See Menu Selections from Main Window and Frequency Scan Mode.)

Icon	Description
	<b>Pilot tone indicator</b> - A steady “P” icon is displayed when a pilot tone from the associated transmitter is present. The icon flashes if no pilot tone is detected and will change to a small “b” if the pilot tone has been bypassed. To bypass the pilot tone, press and hold MENU, then press the SELECT Up button. Press and hold MENU and press SELECT UP again to restore normal pilot tone squelch.
	<b>Antenna Phase indicator</b> - Shows antenna phase switching activity. As the antenna phase is switched, the symbol will flip vertically.
	<b>RF level</b> - Changes in size vertically to indicate the strength of the incoming RF signal. RF levels are engraved from 1 uV to 1000 uV on the bezel to the left of the LCD.
	<b>Audio Levels</b> - Changes in size horizontally to indicate the audio level (modulation) of the signal received from the transmitter. The icon changes to a solid rectangular block when the audio signal is being limited in the transmitter. Levels in dB are engraved into the bezel above the LCD.
	<b>Battery Levels</b> - <b>Rx</b> indicates the receiver battery condition and will flash when approximately one hour of operational time is remaining. The <b>Tx</b> symbol works in the same manner to indicate the transmitter battery condition. The <b>Tx</b> icon usually appears 5 to 10 seconds after the transmitter signal is acquired. When external power is being used, the <b>Rx</b> battery icon changes to look like a power plug.



## MENU SELECTIONS FROM MAIN WINDOW

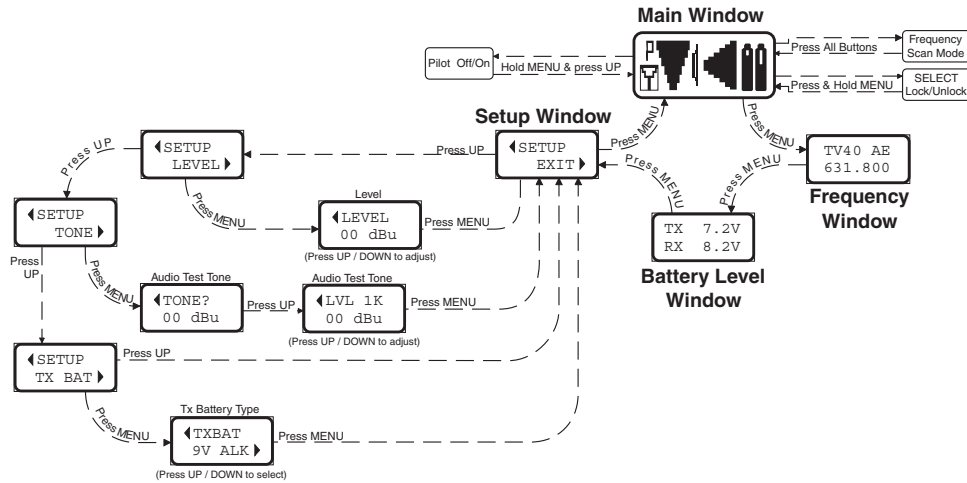

From the Main Window, you can navigate to the Frequency, Battery Level and Setup windows in a circular sequence by pressing the MENU button.

### FREQUENCY WINDOW

TV channel - which television broadcast channel this frequency falls within.

TV40 AE  
631.800

Transmitter switch settings - these are the correct switch settings for the frequency switches on your transmitter - see your transmitter instructions.

Frequency - Press the Select Up and Select Down buttons to change the frequency of the receiver. Be certain to change the transmitter switches to match the settings shown in the upper right hand corner. (If the transmitter frequency differs from the receiver by as much as one "notch" or 100kHz, the pilot tone indicator on the receiver will drop out and the receiver audio will mute.)

### BATTERY LEVEL WINDOW

This window shows the transmitter (TX) and receiver (RX) battery voltage in tenth volt increments. These levels will flash when the voltages drop below suggested optimum working levels. Typically, there will be about one hour operating time remaining after the indicators begin to flash. The RX voltage changes to EX when operating on external power and displays the external power source voltage. (Disclaimer: We don't guarantee 0.1 Volt accuracy.)

TX 7.2V  
RX 8.2V

### SETUP WINDOW

In the SETUP window, the UP and DOWN buttons scroll through a list of four possible destinations: EXIT, LEVEL, TONE and TXBAT. Each of these destinations allows a variety of settings to customize the receiver operating parameters. Press MENU at the screen shown here to return to the main window.

SETUP  
EXIT

### LEVEL

The LEVEL setup screen shows the audio output level of the receiver in dBu. Use the UP or DOWN buttons to change the level. Range is from -50 to +9 dBu in 1dB steps. Press MENU to leave this screen.

LEVEL  
-50 dBu

### tone

The TONE setup screen enables an audio test tone at the receiver output for precise level matching with other equipment. The first screen prompts you to press the UP button to enable the tone at the receiver output jack. The next screen that appears allows the level to be adjusted in 1dB steps using the UP and DOWN buttons. When the audio test tone is enabled, the received audio is muted and an internally generated 1kHz test tone is routed to the XLR connector. Since there is only one audio output level setting for both received audio and tone, the level set here will be retained in the receive mode (it will supersede the setting made in the LEVEL setup screen). The test tone has 5% distortion and is intended for confirmation of output levels only. To exit the test tone screen and stop the tone press the MENU button.

TONE?  
00 dBu

LVL 1K  
00 dBu

### TXBAT

The TXBAT setup screen allows you to select the exact battery being used in the transmitter to provide more accurate battery level monitoring. Four different types of batteries are commonly used in Lectrosonics transmitters: 9 Volt alkaline, 9 Volt lithium, AA alkaline, and AA lithium. Correctly set, this will ensure that the information in the MAIN and BATTERY LEVEL windows will be accurate, and adequate warning will be provided in advance of battery failure. Press MENU to leave this screen.

TXBAT  
9V ALK

## FREQUENCY SCAN MODE

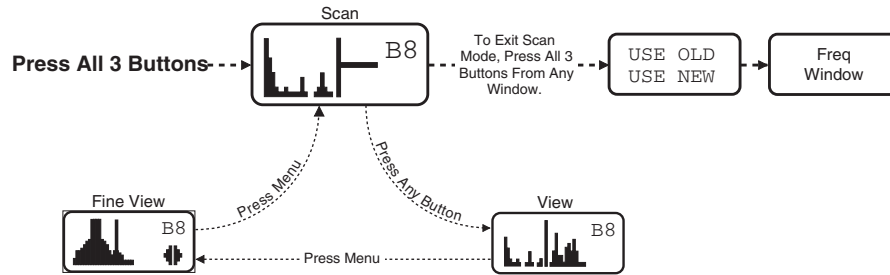

### SCAN AND VIEW WINDOW ELEMENTS

**Cursor** - shows relative position of the scanner within the 25MHz band of the receiver

**Switch Settings** - shows the transmitter switch settings - will change rapidly while the unit is scanning.

**Scan level indications** showing relative level of RF activity across the 25MHz bandwidth of the receiver.

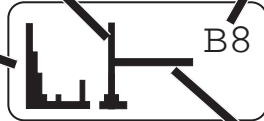

Remaining unscanned part of band.

### FINE VIEW WINDOW ELEMENTS

**Cursor (center bar)**

**Transmitter Switch Settings**

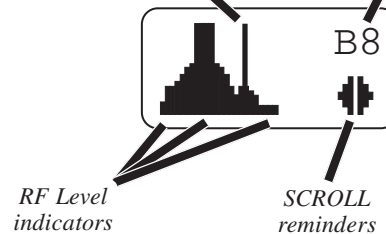

**RF Level indicators**

**SCROLL reminders**

To use the integrated scanning function, press both UP/DOWN buttons and the MENU button at the same time. The display will switch to the SCAN WINDOW and start scanning immediately. Data gathered during a scan is stored until it is purposely erased or the power is turned off. Previous data will remain and subsequent scans can be made to search for additional signals or to accumulate higher peaks.

To stop scanning, press the MENU button once. The scanning will stop immediately, and the display will switch to the VIEW window. In this window, each vertical band of the display represents eight frequencies (800 kHz). Pressing the UP or DOWN buttons will scroll the cursor coarsely across the tuning range. The transmitter switch settings matching the frequency indicated by the cursor are shown in the upper right corner of the screen.

Spectrum data is collected only when the receiver is scanning. Successive scanning with repeated passes through the tuning range will accumulate the highest peaks encountered to aid in finding clear frequencies. To clear the scan memory without leaving scan mode, turn the power switch off and back on quickly.

Pressing the MENU button once will shift the display to the FINE VIEW window which will show an expanded portion of the spectrum around the cursor.

In the FINE VIEW window, each vertical band represents one frequency the receiver is capable of tuning. The upper right corner shows the transmitter switch settings for the. In this screen, a vertical center bar is the cursor. Underneath the switch settings are two arrows to remind

you that this is a partial picture of the spectrum and that you can scroll left or right to view the entire spectrum of the receiver by pressing the UP and DOWN buttons.

Pressing the UP button will make the display scroll left, showing higher frequencies. Pressing the DOWN button will make the display scroll right, showing lower frequencies. The cursor remains in place while the display scrolls left or right

In addition to assessing the congestion within the RF tuning range of the receiver, the scanning mode is also used to find a clear operating frequency. Scroll through the screen and find a frequency where no RF signals are present (or in the worst case, only very weak RF signals). With the cursor on this frequency, press the UP, DOWN and MENU buttons at the same time to leave the scan mode.

When leaving the scan mode, you are given the option of using the frequency the unit was on before entering the scan mode, or using the frequency just selected in the scan mode. The display shows USE OLD and USE NEW to prompt you to make a frequency selection. To accept the new frequency just selected in the scan mode, press the DOWN button for USE NEW. To return to the frequency you were using before entering the scan mode, press the UP button for USE OLD. (the MENU button defaults to USE OLD).

Once you leave the scan mode, the Frequency Window will be displayed. Set your transmitter switches to the same settings as shown on the display and your system will be ready for operation.

## ANTENNA USE AND PLACEMENT

The receiver is supplied with two straight BNC antennas. In some circumstances remote antennas such as the SNA600 or ALP700 may be useful for improving reception. Position remote antennas at least three or four feet apart and so that they are also not within 3 or 4 feet of large metal surfaces. If this is not possible, try to position the antennas so that they are as far away from the metal surface as is practical. It is also good to position the receiver so that there is a direct "line of sight" between the transmitter and the receiver antenna. In situations where the operating range is less than about 100 feet, the antenna positioning is much less critical. The antennas can also be configured with one whip mounted directly onto the panel of the receiver, and the other one mounted remotely.

Be careful about the length of cabling from antenna to receiver. Long cable runs can have serious signal loss. Lectrosonics has in-line RF amplifiers suitable for compensating for long cable runs. Contact your dealer or the factory for more information.

A wireless transmitter sends a radio signal out in all directions. This signal will often bounce off nearby walls, ceilings, etc. and a strong reflection can arrive at the receiver antenna along with the direct signal. If the direct and reflected signals are out of phase with each other a cancellation may occur. The result would be a

"dropout." A dropout sounds like either audible noise (hiss), or in severe cases, may result in a complete loss of the carrier and the sound when the transmitter is positioned in certain locations in the room. A UHF dropout normally sounds like a short "hiss" or a "swishing" sound. Moving the receiver, or, if remote antennas are used, the antennas even a few inches will change the sound of the hum or hiss, or eliminate it. A dropout situation may also become either better or worse as the crowd fills and/or leaves the room, or when the transmitter or receiver is operated in a different location.

The receiver offers a sophisticated diversity design which overcomes dropout problems in almost any situation. In the event, however, that you do encounter a dropout problem, first try moving the receiver (or antennas if remote antennas are used) at least three or four feet from where their original position. This may alleviate the dropout problem at that location. If dropouts are still a problem, try moving the unit (or antennas) to an entirely different location in the room or moving the receiver closer to the transmitter location.

Lectrosonics transmitters radiate power very efficiently, and the receivers are very sensitive. This reduces dropouts to an insignificant level. If, however, you do encounter dropouts frequently, call the factory or consult your dealer. There is probably a simple solution.

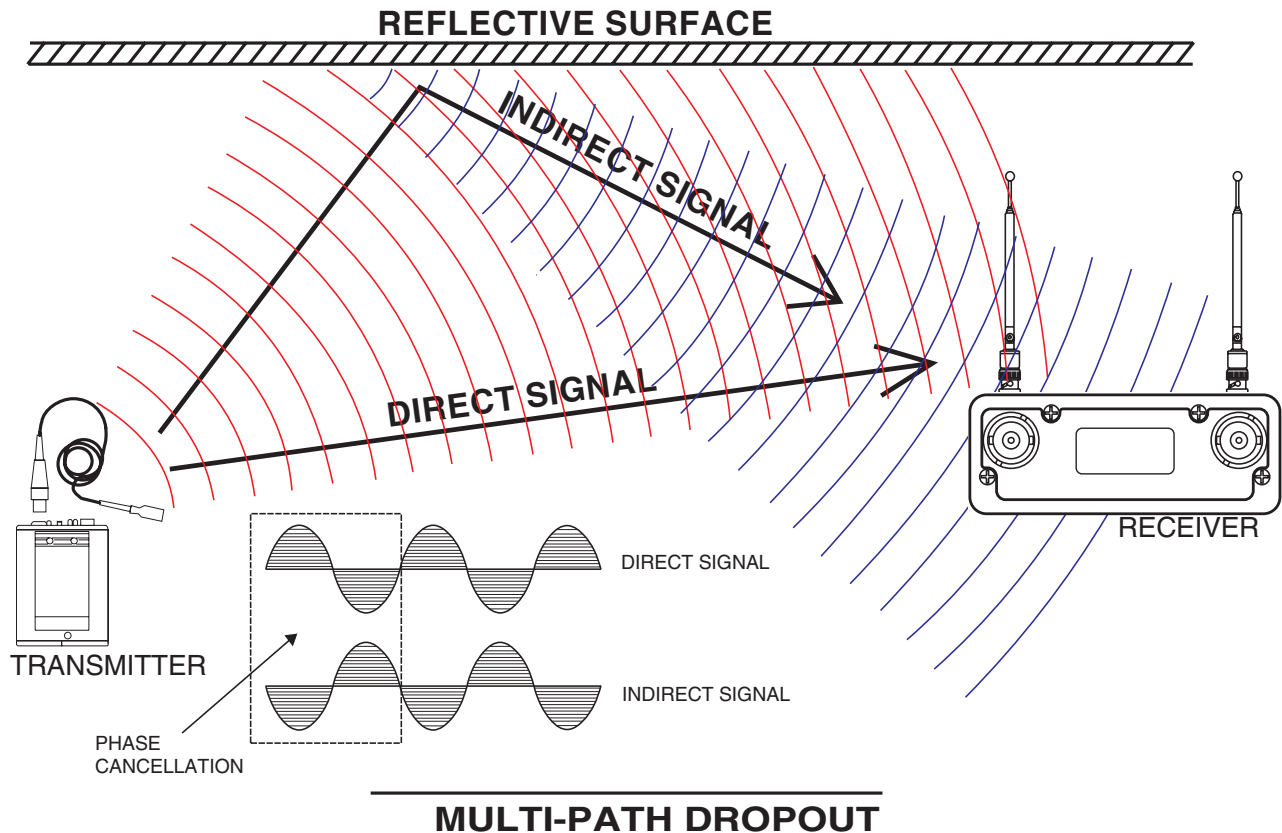

## INSTALLATION AND OPERATING INSTRUCTIONS

1. Install a fresh battery or connect an external power source to the UCR211.
2. Unless frequency settings have been previously assigned, scan for an open frequency and set both the receiver and transmitter to that frequency. (See Finding Clear Frequencies.)
3. Connect the audio cable to the Receiver Audio Out XLR jack.
4. Set the Power ON/OFF switch to ON and verify that the LCD panel activates.
5. Adjust the transmitter gain. **THIS IS PERHAPS THE MOST IMPORTANT STEP IN THE SET UP PROCEDURE.** Refer to your transmitter manual's Operating Instructions section for details on how to adjust the transmitter gain. In general, adjust the transmitter gain so that the voice peaks will cause the audio modulation indicators on the receiver and transmitter to show full modulation on the loudest peak audio levels. Normal levels should cause the UCR211's audio level icon to fluctuate fully. This will result in the best possible signal to noise ratio for the system.

### Note

A common mistake at this point is to use the transmitter audio gain control to set the overall audio level of the entire audio system. The transmitter gain control is not a volume control and must be set independently of the overall system audio level. The transmitter gain control is only used to set the proper modulation of the transmitter. To explain it another way, it is used to match the transmitter to the type of microphone and the sound levels that will be present at that microphone. We encourage users to either disconnect the rest of the sound system or turn the sound system gain to minimum to prevent feedback or overload as the transmitter gain is set.

That way, feedback from the sound system or overload of other equipment does not get in the way of setting the transmitter gain properly. Only after the transmitter gain control is set should the gain of the rest of the audio system be adjusted to achieve the desired sound or signal levels.

6. Adjust the Audio Output according to the type of input on your equipment. Use the LEVEL menu and adjust the level with the SELECT Up and Down buttons.

The input levels of different cameras, VCRs, and PA equipment vary, which may require that you adjust the AUDIO OUT to an intermediate position. Try different settings and listen to the results. If the output of the receiver is too high, you may hear distortion or a loss of the natural dynamics of the audio signal. If the output is too low, you may hear steady noise (hiss) along with the audio. The UCR211 audio output is designed to drive any audio input device from microphone level to +10dBu line level.

### Note

The test tone output is especially useful for an exact level match. With the test tone running, adjust for the maximum desired peak level using the metering on the connected device.

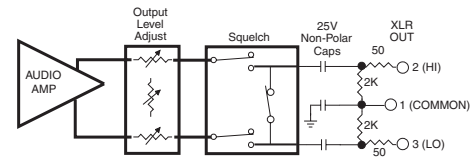

UCR211 Simplified Audio Output Circuit

## FINDING CLEAR FREQUENCIES

The following procedure will help you identify RF signals in the area and find clear channels for operating the wireless system.

1. Ensure transmitter is turned off. Turn on the receiver and wait a few seconds until the Main Window appears on the LCD
2. Ensure the receiver is not in PILOT TONE BYPASS mode. (A "P" will be blinking in the upper left corner of the Main Window.)

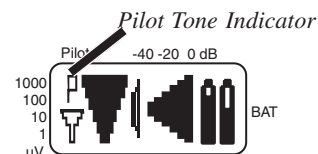

3. Simultaneously press the MENU and SELECT Up and Down buttons to enter Scan Mode.

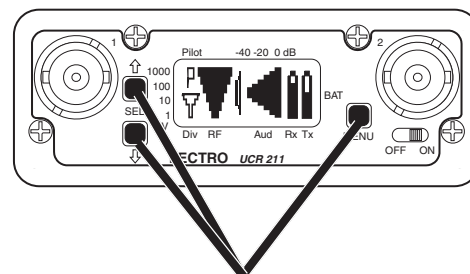

Press all three buttons at the same time and the receiver will start scanning.

4. View the LCD while the receiver is scanning. The vertical marker will move across the display from left to right. RF activity will be indicated by dark areas in the display.

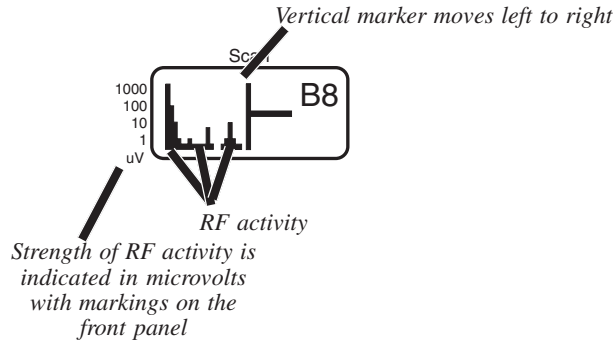

- RF signal strength is indicated by markings in microvolts on the front panel to the left of the LCD. Look for clear channels in the spectrum where there is no RF activity. Scanning will repeat and continue until a button is pressed.

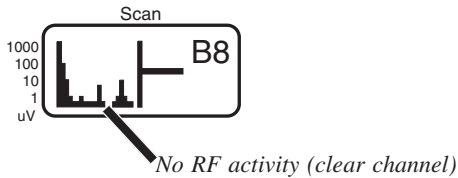

- If necessary, press the MENU button to zoom in for greater detail for fine adjustment.

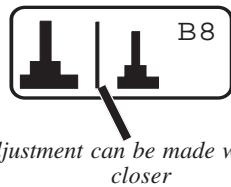

- Then press the SEL Up and Down arrows to move the marker to the middle of a clear area where there is no RF activity. If an area with no RF activity cannot be found anywhere in the spectrum, locate one with the least amount of RF activity.

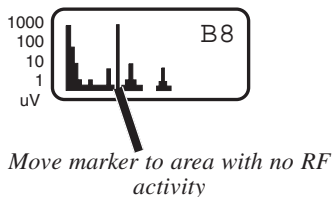

- Press all three buttons (SEL Up and Down and MENU) to move to the next screen. Two options will be shown.

Press the SEL Down arrow button to select the USE NEW option and set the receiver to the new frequency just found in scanning.

Press the SEL Up arrow button to select USE OLD and return to the frequency that was set before scanning.

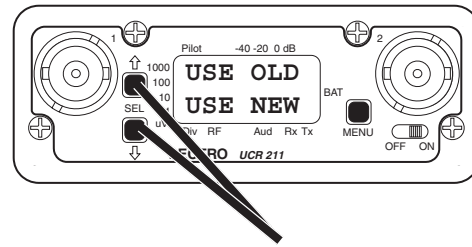

Use the SEL Up and Down arrow buttons to select the old or new frequency.

## LOCKING AND UNLOCKING THE UCR211 FRONT PANEL CONTROLS

The front panel controls can be “LOCKED” to prevent accidental changes being made during operation and handling.

**To LOCK** - Press and hold the MENU button until a bar tracks horizontally across the LCD screen and the word “LOCKED” appears. If the MENU button is released before the word “LOCKED” appears, the unit will remain UNLOCKED. When in a LOCKED state, the pilot tone bypass toggle is also defeated.

In LOCKED state, the use of the MENU and SELECT Up/Down buttons are limited to “view only” and attempts to change selections will result in a screen displaying the word “LOCKED.” The unit cannot be used for RF scanning when it is set in the LOCKED state.

**To UNLOCK** - Press and hold the MENU button until a bar tracks horizontally across the screen and the word “UNLOCKED” appears. When the unit is UNLOCKED, all settings can be altered.

The receiver can be LOCKED or UNLOCKED from any of the four primary windows. It cannot be LOCKED from the scanning mode or from other subordinate screens.



## REPLACING THE BATTERY

Lift and open the bottom battery door cover with your thumb, rotate the door clockwise until it is perpendicular with the case and allow the battery to fall out of the compartment into your hand. Retaining pins will prevent you from opening too far. It is difficult to install the battery backwards. Observe the large and small holes in the battery contact pad before inserting a new battery. Insert the contact end of the battery first, making sure the contacts are aligned with the holes in the contact pad, and then swing the door closed. You will feel it snap into place when it is fully closed.

### CAUTION

*Lithium batteries will expand and swell if allowed to go into a deep discharge. Be sure to remove lithium batteries as soon as the display starts flashing. If lithium batteries are allowed to fully discharge while still inside the battery compartment, they may be very difficult to remove. Stuck lithium batteries can be avoided by removing the battery label wrapping before use. This will allow the battery to swell but will still leave enough room in the compartment for the battery to fall out normally.*

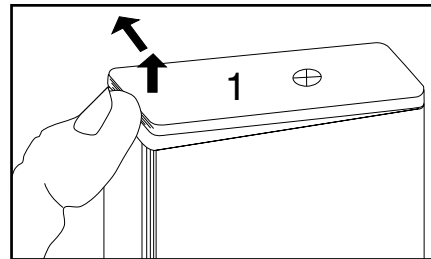

To open the battery compartment door, push the door up and away from the case with your thumb, then swing open.

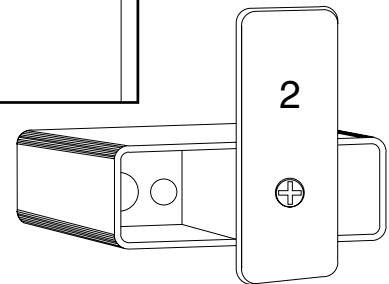

---

## UCR211 REPLACEMENT PARTS and ACCESSORIES

Part No.	Description
<b>32251</b>	Velcro mounting strips
<b>35753</b>	Zippered, padded vinyl system pouch
<b>CH12</b>	AC power supply
<b>VSR1</b>	Thin velcro loop for power cable strain relief.
<b>A8U</b>	UHF marine phosphor bronze antenna - straight connector, specify block.



## TROUBLESHOOTING

### POWER SUPPLY AND FUSE LCD display not active

- External power supply disconnected or inadequate.
- Main power supply fuse tripped. Turn the receiver off, remove the cause of the overload and turn the receiver back on.
- Wrong polarity power source. The external DC in requires POSITIVE to be on the center pin.
- Battery may be low. Try a fresh battery

### PILOT TONE SQUELCH PILOT indicator is solid “P”, but no sound

- Audio output cable bad or disconnected.
- Audio Output level set too low. Use the built-in test tone to verify levels.

### PILOT “P” keeps flashing when transmitter audio switch is turned on

- It takes several seconds for the relay to actuate the PILOT. Turn on the transmitter power (and the audio switch on some models) and wait 3 to 5 seconds for the “P” to indicate steadily.
- Transmitter and receiver not on same frequency.

### Noise on audio and Pilot indicator is “b”

- The pilot tone bypass has been activated. Hold MENU and press UP to reset (works only from the Main Window).

#### *Note*

*The PILOT indicator on the front panel shows as a solid “P” to indicate that the audio has been turned on at the transmitter, and that the audio output on the receiver is enabled. When the “P” is on, the audio is enabled. If the “P” is flashing the pilot tone is not detected and the audio will be muted (squelched).*

*When the pilot tone is bypassed, the “P” icon changes to a “b” shape.*

### ANTENNAS AND RF SIGNAL STRENGTH RF Level is weak

- Receiver may need to be moved or reoriented.
- Transmitter antenna may be defective or poorly connected
- Improper length of antenna, or wrong antenna on transmitter. (UHF whip antennas are generally about 3 to 5 inches long. UHF helical antennas may be shorter, but are often less efficient.

#### No RF Signal

- Make certain frequency switches on transmitter match the receiver frequency setting.
- Check battery in transmitter

### AUDIO SIGNAL QUALITY Poor signal to noise ratio

- Transmitter gain set too low
- The noise may not be in the wireless system. Turn the transmitter audio gain all the way down and see if the noise remains. If the noise remains, then turn the power off at the transmitter and see if it remains. If the noise is still present, then the problem is not in the transmitter.
- If noise is still present when the transmitter is turned off, try lowering the audio output level on the UCR201 and see if the noise lowers correspondingly. If the noise remains, the problem is not in the receiver.
- Receiver output is too low for the input of the device it is feeding. Try increasing the output level of the UCR201 and lowering the input gain on the device the UCR211 is feeding.

#### Distortion

- Transmitter input gain too high. Check and/or readjust input gain on transmitter according to the LEDs on the transmitter and then verify the setting with the audio meter in the main window.
- Audio output level too high for the device the UCR201 is feeding. Lower the output level of the UCR211.

## SPECIFICATIONS AND FEATURES

<b>Operating Frequencies (MHz):</b>	Block 21: 537.600 - 563.100 Block 22: 563.200 - 588.700 Block 23: 588.800 - 607.900 and 614.100 - 614.300 Block 24: 614.400 - 639.900 Block 25: 640.000 - 665.500 Block 26: 665.600 - 691.100 Block 27: 691.200 - 716.700 Block 28: 716.800 - 742.300 Block 29: 742.400 - 767.900
<b>Frequency Adjustment Range:</b>	25.5 MHz in 100 kHz steps
<b>Receiver Type:</b>	Triple conversion, superheterodyne, 244 MHz , 10.7 MHz and 300 kHz
<b>Frequency Stability:</b>	±0.001 %
<b>Front end bandwidth:</b>	±5.5MHz @ -3dB
<b>Sensitivity</b>	
20 dB Sinad:	0.9 uV (-108 dBm), A weighted
60 dB Quieting:	1.12 uV (-105 dBm), A weighted
<b>Squelch quieting:</b>	Greater than 125 dB
<b>AM rejection:</b>	Greater than 60 dB, 2 uV to 1 Volt (Undetectable after processing)
<b>Modulation acceptance:</b>	85 kHz
<b>Image and spurious rejection:</b>	85 dB
<b>Third order intercept:</b>	+8 dBm
<b>Diversity method:</b>	Phased antenna diversity
<b>FM Detector:</b>	Digital Pulse Counting Detector operating at 300 kHz
<b>Antenna inputs:</b>	Dual BNC female, 50 Ohm impedance
<b>Audio outputs</b>	
<b>Rear Panel XLR:</b>	Adjustable from -50 dBu to +9 dBu in 1 dB steps. Calibrated into a typical 10K Ohm balanced load. Actual output impedance max 500 Ohms, min 200 Ohms.
<b>Front Panel Controls and Indicators</b>	
<b>LCD control panel menus include:</b>	
<b>Main window:</b>	Pilot tone; antenna phase, receiver battery level; transmitter battery level; audio level, RF level
<b>Frequency window:</b>	Frequency, TV channel; Transmitter switch setting
<b>Audio output level adjustment:</b>	-50 dBu to +9 dBu
<b>Battery level tracking:</b>	Both transmitter and receiver in 1/10th volt steps, accuracy +/- 10%.
<b>Scanning mode:</b>	Coarse and fine modes for spectrum check
<b>Audio test tone:</b>	1 kHz, -50 dBu to +10 dBu output, < 5% THD
<b>Transmitter battery type selection:</b>	9V alkaline, 9V lithium, AA alkaline, AA lithium
<b>Rear Panel Controls and features:</b>	XLR audio output jack; External DC input; Battery compartment access
<b>Power Options</b>	
<b>Ext DC:</b>	Minimum 10 Volts to maximum 18 Volts DC; 1.6 W, 130 mA at 12VDC
<b>Int Batt:</b>	9V alkaline or lithium (110 mA @ 9V, 160mA @ 6V)
<b>Battery Life</b>	
<b>9V alkaline:</b>	6 to 8 hours continuous, up to 12 hours intermittent
<b>9V lithium:</b>	Up to 20 hours (continuous and intermittent usage are the same)
<b>Weight:</b>	14 oz. with batteries
<b>Dimensions:</b>	3.23" wide x 1.25" high x 4.64" deep
<b>System Audio Specifications</b> (UCR211 Receiver / UM200C Transmitter)	
<b>Signal to Noise Ratio:</b>	108 dB; A-weighted at full quieting
<b>Distortion:</b>	Less than 0.5% at 50% modulation, 1 kHz
<b>Frequency Response:</b>	+/- 3 dB from 40 Hz to 18 kHz

Specifications subject to change without notice.

## SERVICE AND REPAIR

If your system malfunctions, you should attempt to correct or isolate the trouble before concluding that the equipment needs repair. Make sure you have followed the setup procedure and operating instructions. Check out the interconnecting cords and then go through the TROUBLESHOOTING section in the manual

We strongly recommend that you **do not** try to repair the equipment yourself and **do not** have the local repair shop attempt anything other than the simplest repair. If the repair is more complicated than a broken wire or loose connection, send the unit to the factory for repair and service. Don't attempt to adjust any controls inside the units. Once set at the factory, the various controls and trimmers do not drift with age or vibration and never require readjustment. **There are no adjustments inside that will make a malfunctioning unit start working.**

LECTROSONICS' service department is equipped and staffed to quickly repair your equipment. In warranty repairs are made at no charge in accordance with the terms of the warranty. Out-of-warranty repairs are charged at a modest flat rate plus parts and shipping. Since it takes almost as much time and effort to determine what is wrong as it does to make the repair, there is a charge for an exact quotation. We will be happy to quote approximate charges by phone for out-of-warranty repairs.

## RETURNING UNITS FOR REPAIR

You will save yourself time and trouble if you will follow the steps below:

**A.** DO NOT return equipment to the factory for repair without first contacting us by letter or by phone. We need to know the nature of the problem, the model number and the serial number of the equipment. We also need a phone number where you can be reached 8 am to 4 pm (Mountain Standard Time).

**B.** After receiving your request, we will issue you a return authorization number (R.A.). This number will help speed your repair through our receiving and repair departments. The return authorization number must be clearly shown on the outside of the shipping container.

**C.** Pack the equipment carefully and ship to us, shipping costs prepaid. If necessary, we can provide you with the proper packing materials. UPS is usually the best way to ship the units. Heavy units should be "double-boxed" for safe transport.

**D.** We also strongly recommend that you insure the equipment, since we cannot be responsible for loss of or damage to equipment that you ship. Of course, we insure the equipment when we ship it back to you.

**Mailing address:**

Lectrosonics, Inc.  
PO Box 15900  
Rio Rancho, NM 87174  
USA

**Shipping address:**

Lectrosonics, Inc.  
581 Laser Rd.  
Rio Rancho, NM 87124  
USA

**Telephones:**

Regular: (505) 892-4501  
Toll Free: (800) 821-1121  
FAX: (505) 892-6243

**Web:** <http://www.lectrosonics.com>

**E-mail:** [sales@lectrosonics.com](mailto:sales@lectrosonics.com)



## LIMITED ONE YEAR WARRANTY

The equipment is warranted for one year from date of purchase against defects in materials or workmanship provided it was purchased from an authorized dealer. This warranty does not cover equipment which has been abused or damaged by careless handling or shipping. This warranty does not apply to used or demonstrator equipment.

Should any defect develop, Lectrosonics, Inc. will, at our option, repair or replace any defective parts without charge for either parts or labor. If Lectrosonics, Inc. cannot correct the defect in your equipment, it will be replaced at no charge with a similar new item. Lectrosonics, Inc. will pay for the cost of returning your equipment to you.

This warranty applies only to items returned to Lectrosonics, Inc. or an authorized dealer, shipping costs prepaid, within one year from the date of purchase.

This Limited Warranty is governed by the laws of the State of New Mexico. It states the entire liability of Lectrosonics Inc. and the entire remedy of the purchaser for any breach of warranty as outlined above. NEITHER LECTROSONICS, INC. NOR ANYONE INVOLVED IN THE PRODUCTION OR DELIVERY OF THE EQUIPMENT SHALL BE LIABLE FOR ANY INDIRECT, SPECIAL, PUNITIVE, CONSEQUENTIAL, OR INCIDENTAL DAMAGES ARISING OUT OF THE USE OR INABILITY TO USE THIS EQUIPMENT EVEN IF LECTROSONICS, INC. HAS BEEN ADVISED OF THE POSSIBILITY OF SUCH DAMAGES. IN NO EVENT SHALL THE LIABILITY OF LECTROSONICS, INC. EXCEED THE PURCHASE PRICE OF ANY DEFECTIVE EQUIPMENT.

This warranty gives you specific legal rights. You may have additional legal rights which vary from state to state.

## LECTROSONICS, INC.

581 LASER ROAD  
RIO RANCHO, NM 87124 USA  
[www.lectrosonics.com](http://www.lectrosonics.com)

August 31, 2004